

SV 500/2

Side channel vacuum pumps

- double stage, air-cooled
- with pedestal

Seitenkanal-Vakuumpumpen

- zweistufig, luftgekühlt
- mit Standfuß

Pompes à vide à canal latéral

- double-étagées, refroidies par air
- avec pied

Aspiratori a canale laterale

- doppiostadio, raffreddate ad aria
- con piedistallo

Bombas de vacío de canal lateral

- dos etapas, refrigerado por aire
- con pie



SV 500/2 incl. pedestal and optional rubber buffers

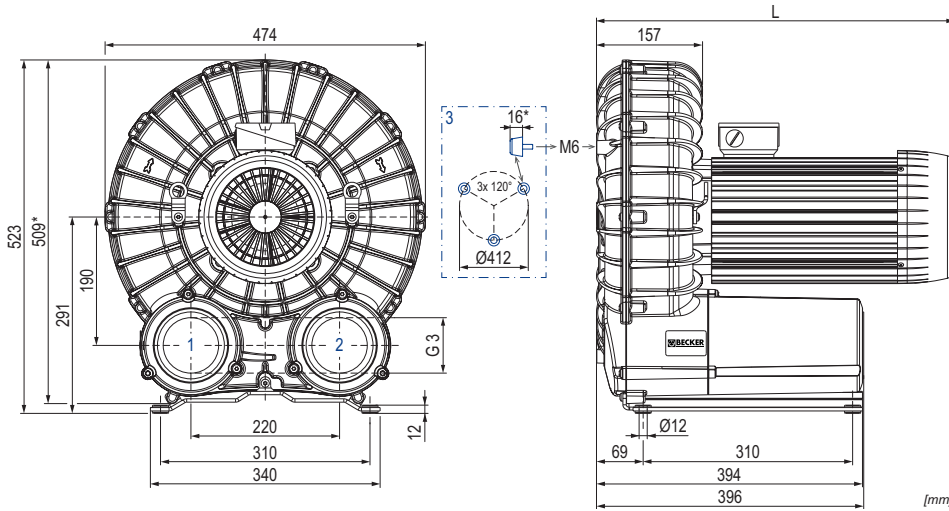

- 1 Vacuum connection
Sauganschluss
Raccord vide
Raccordo aspirazione
Conexión de vacío
- 2 Pressure connection
Druckanschluss
Raccord pression
Raccordo pressione
Conexión presión
- 3 Rubber buffer position (optional)
Gummipufferposition (optional)
Position de tampon en caoutchouc (optionnel)
Posizione del respingente in gomma (opzionale)
Posición del tope de goma (opcional)

m ³ /h		mbar rel.		kW 3~			L	kg	dB(A) ¹⁾	
50 Hz	60 Hz	50 Hz	60 Hz	50 Hz	60 Hz	(M)	mm		50 Hz	60 Hz
		-280	-240	3.0	3.6	1-4	485	58.0		
260	305	-410	-400	4.0	4.8	5-8	496	62.5	68.9 (-265 mbar)	71.7 (-230 mbar)
		-410 (-450) ²⁾	-400 (-450) ²⁾	5.5	6.6	9-12	530	67.5	69.5 (-280 mbar)	70.4 (-295 mbar)

(M)	kW	50 Hz				60 Hz				No	No	
		V ±10%	min ⁻¹	A	kW	V ±10%	min ⁻¹	A				
1	3~ 3.0	Δ230/Y400	IE3/UL/CSA	2940	10.9/6.3	3.6	Δ265/Y460 Δ230/Y400	IE3/UL/CSA IE3/UL/CSA	3505 3530	10.8/6.25 11.5/6.6	42489201605000GV	G023138
2	3~	-	-	-	-	3.6	YY230/Y460 208	IE3/UL/CSA IE3/UL/CSA	3525 3505	12.0/6.0 12.7	42589207605000GV	G023139
3	3~ 3.0	Δ200/Y350	IE3	2940	12.6/7.3	3.6	Δ220/Y380-400 Δ200/Y350	IE3 -	3530 3505	12.6/7.3-7.2 13.2/7.55	42489285605000GV	G023140
4	3~	-	-	-	-	3.6	Δ400/Y690	IE3	3530	7.2/4.2	42589212605000GV	G023141
5	3~ 4.0	Δ230/Y400	IE3/UL/CSA	2930	14.6/8.4	4.8	Δ265/Y460 Δ230/Y400	IE3/UL/CSA IE3/UL/CSA	3520 3490	14.3/8.25 15.4/8.85	42689201605000GV	G023083
6	3~	-	-	-	-	4.8	YY230/Y460 208	IE3/UL/CSA -	3520 3500	16.5/8.25 17.1	42789207605000GV	G023084
7	3~ 4.0	Δ200/Y350	IE3	2930	16.6/9.6	4.8	Δ220/Y380-400 Δ200/Y350	IE3 IE3	3520 3490	16.6/9.6-9.45 17.7/10.1	42689285605000GV	G023085
8	3~	-	-	-	-	4.8	Δ400/Y690	IE3	3510	9.15/5.3	42789212605000GV	G023086
9	3~ 5.5	Δ400/Y690	IE3/UL/CSA	2930	11.9/6.9	6.6	Δ460 Δ400/Y690	IE3/UL/CSA IE3/UL/CSA	3520 3520	11.5 10.2/5.9	42889202605000GV	G023110
10	3~	-	-	-	-	6.6	YY230/Y460 208	IE3/UL/CSA -	3520 3495	23.0/11.5 23.4	42989207605000GV	G023111
11	3~ 5.5	Δ200/Y350	IE3	2935	26.9/15.4	6.6	Δ220/Y380-400 Δ200/Y350	IE3 IE3	3530 3500	24.0/14.3-13.9 24.7/14.1	42889285605000GV	G023112
12	3~	-	-	-	-	6.6	Δ400/Y690	IE3			42989212605000GV	G023113

- 1) DIN EN ISO 3744 (KpA = 3 dB(A)) interval of 1m, at medium load, both connection sides piped
 - 2) Short time operation, cycle:
60s → -450mbar and
180s → <-400mbar
- * Device dimensions without pedestal under the silencer, with rubber buffers on the enclosure cover
- | | | | | |
|---|---|---|---|---|
| DIN EN ISO 3744 (KpA = 3 dB(A))
Abstand von 1m, bei mittlerer Belastung, beide Seiten abgeleitet | DIN EN ISO 3744 (KpA = 3 dB(A))
intervalle de 1m, à régime moyen, avec dérivation des deux côtés | DIN EN ISO 3744 (KpA = 3 dB(A))
intervallo di 1m, a medio regime, entrambi i lati derivati | DIN EN ISO 3744 (KpA = 3 dB(A))
intervallo di 1m, a medio regime, entrambi i lati derivati | DIN EN ISO 3744 (KpA = 3 dB(A))
intervallo di 1m, a medio regime, entrambi i lati derivati |
| Geräteabmaße ohne Standfuß unter den Schalldämpfern, mit Gummipuffern am Gehäusedeckel | Dimension d'appareil sans pied sous les silencieux, avec tampons en caoutchouc sur le couvercle | Dimensioni del dispositivo senza piedistallo sotto gli insonorizzatori, con respingenti in gomma sul coperchio dell'alloggiamento | Dimensioni del dispositivo senza piedistallo sotto gli insonorizzatori, con respingenti in gomma sul coperchio dell'alloggiamento | Dimensiones del aparato sin pie bajo los silenciadores, con toques de goma en la tapa de la carcasa |
| Maßangaben in mm | Mesures en mm | Misure in mm | Misure in mm | Dimensiones en mm |

Suction air rate • Saugluftmenge • Débit d'air aspiré • Volume d'aria aspirata • Volumen de aire aspirado

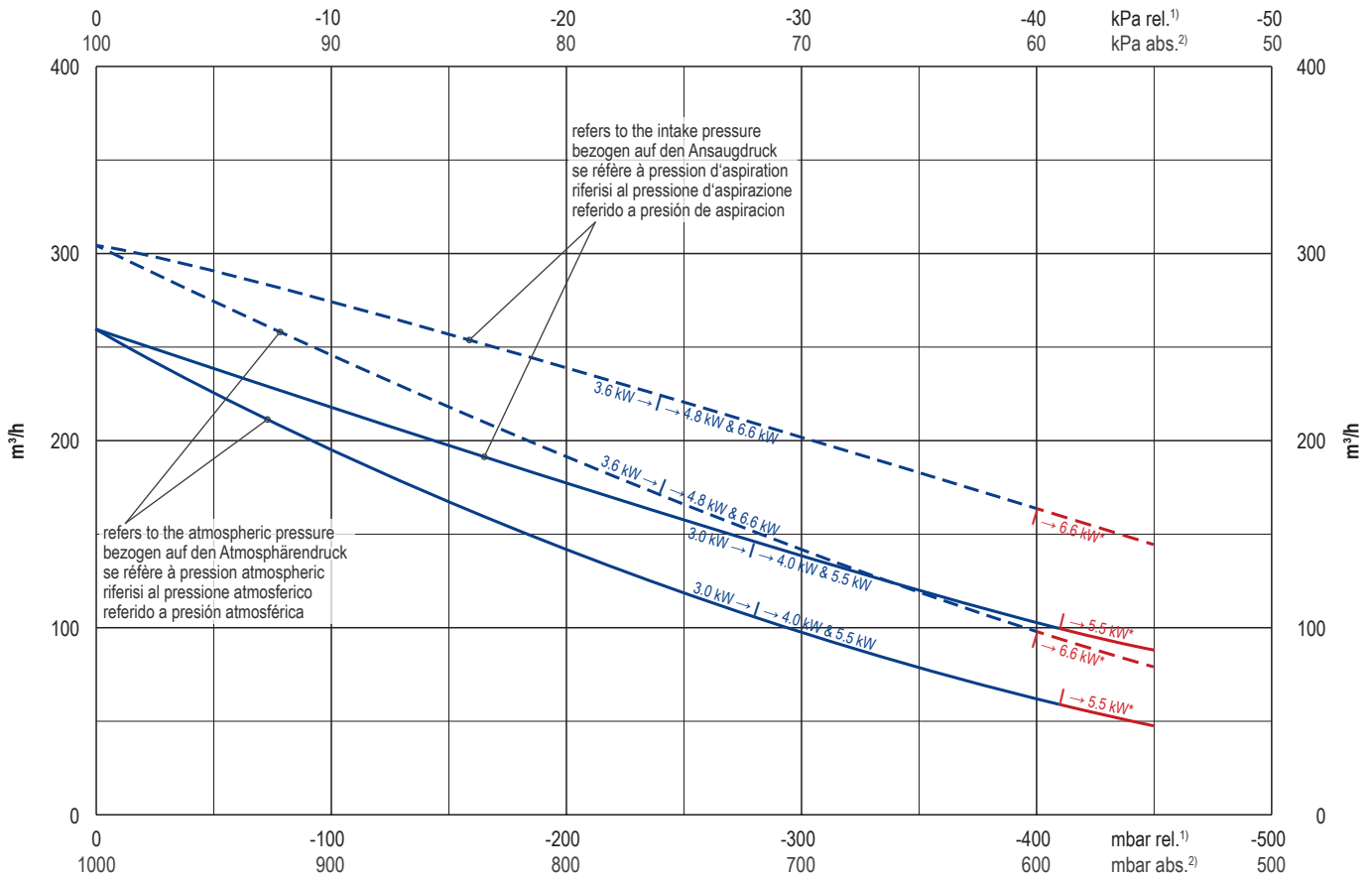

Exhaust air temperature • Ablufttemperatur • Température d'air à l'échappement
Temperatura dell'aria scarica • Temperatura del aire de escape

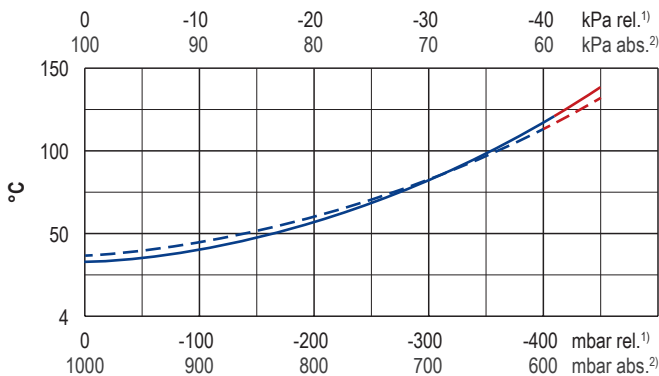

Motor shaft power • Wellenleistung • Puissance du moteur axe
Potenza del motore albero • Capacidad de eje del motor

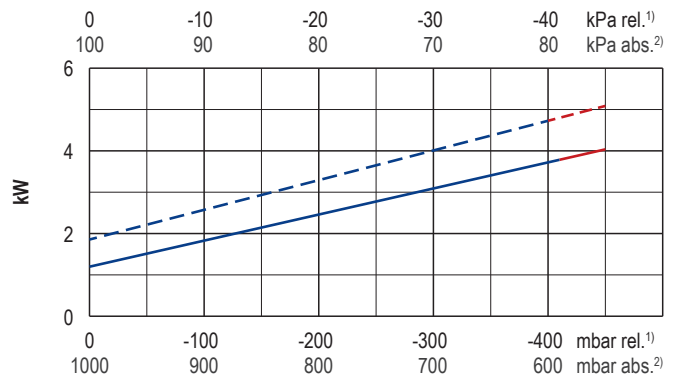

— 50 Hz - - - 60 Hz	1) relative 2) absolute ▪ Reference data (atmosphere) ▪ Tolerance * Short time operation, cyclo	relative absolote Bezugsdaten (Atmosphäre) Toleranz Kurzzeitbetrieb, Zyklus	relatif absolu Réfèrence (atmosphère) Tolérance Service temporaire, cyclo	relativo assoluto Riferimento (atmosfera) Tolleranza Operazione a breve tempo, ciclo	relativa absoluta Referencia (atmosférica) Tolerancia Operación a corto plazo, ciclo	1000 mbar, 20°C ±10 % 60s → -450mbar & 180s → <-400mbar
------------------------	---	---	--	---	---	--

Variants/Accessories

- with internal safety valve
- with internal suction filter
- with increased corrosion protection
- without pedestal under the silencers, with rubber buffers on the enclosure cover

Varianten/Zubehör

- mit internem Sicherheitsventil
- mit internem Ansaugfilter
- mit erhöhtem Korrosionsschutz
- ohne Standfuß unter den Schalldämpfern, mit Gummipuffern am Gehäusedeckel

Variantes/Accessoires

- avec soupape de sécurité interne
- avec filtre d'aspiration interne
- avec protection accrue contre la corrosion
- sans pieds sous les silencieux, avec tampons en caoutchouc sur le couvercle

Varianti/Accessori

- con valvola di sicurezza interno
- con filtro di aspirazione interno
- con una maggiore protezione anti-corrosione
- senza piedistallo sotto gli insonorizzatori, con respingenti in gomma sul coperchio dell'alloggiamento

Variantes/Accesorios

- con válvula de seguridad interna
- con filtro de aspiración interna
- con el aumento de protección contra la corrosión
- sin pie bajo los silenciadores, con topes de goma en la tapa de la carcasa

Performance data / dimensions can differ
Combinations on request

Leistungsdaten / Abmessungen können abweichen
Kombinationen auf Anfrage

Données de performance / mesures peuvent différer
Combinaisons sur demande

Dati di performance / misure possono differire
Combinazioni su richiesta

Datos de rendimiento / dimensiones pueden diferir
Combinaciones a petición



WWW.BECKER-INTERNATIONAL.COM

Right of modification reserved /
Änderungen vorbehalten
Sous réserve des modifications
Sotto riserva di modificazioni
Derecho a modificaciones reservado 21.09.2017

SV 500

Vacuum accessories

- internal vacuum safety valve and/or
- internal suction filter in a vacuum-sealed filter housing (SV 500/2)

Vakuüm-Zubehör

- internes Vakuumsicherheitsventil und/oder
- interner Ansaugfilter in einem vakuumdichten Filtergehäuse (SV 500/2)

Accessoires de vide

- soupape de sécurité vide interne et/ou
- filtre d'aspiration interne dans un boîtier de filtre au vide (SV 500/2)

Accessori per vuoto

- valvola di sicurezza vuoto interno e/o
- filtro di aspirazione interno in una scatola del filtro di aspirazione a tenuta di vuoto (SV 500/2)

Accesorios de vacío

- válvula de seguridad vacío interna y/o
- filtro de aspiración interna en carcasa de filtro hermética al vacío (SV 500/2)



SV 500/1 & SV 500/2

With vacuum safety valve

Mit Vakuumsicherheitsventil

Avec soupape de sécurité vide

Con valvola di sicurezza vuoto

Con válvula de seguridad vacío

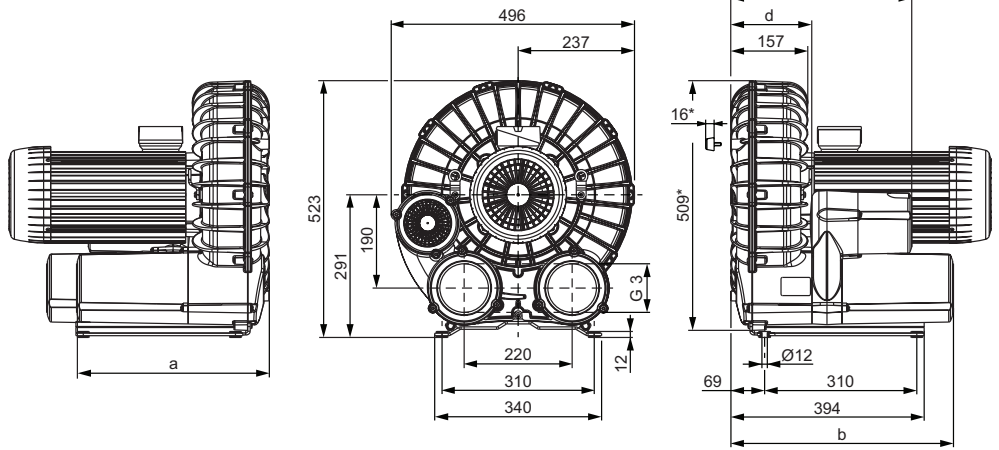
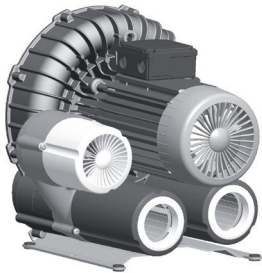

SV 500/2 with internal suction filter³⁾

SV 500/2 mit internem Ansaugfilter³⁾

SV 500/2 avec filtre d'aspiration interne³⁾

SV 500/2 con filtro di aspirazione interno³⁾

SV 500/2 con filtro de aspiración interno³⁾

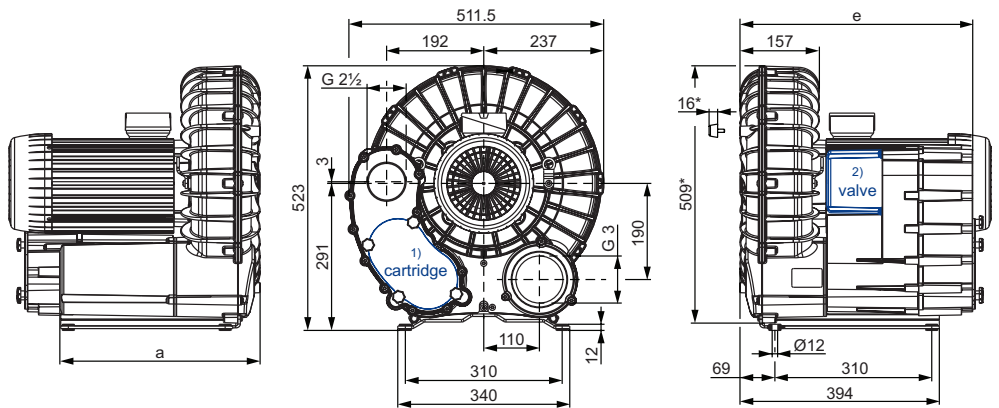
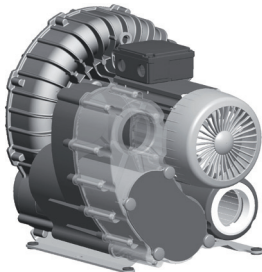

	mm				
	a	b	c	d	e
SV 500/1	391	452	369	165	-
SV 500/2	396	457	374	170	460

1) Cartridge: 90951030000 (paper) 90951030001 (polyester) Space for removing filter housing (removal height): ≈ 300 mm	Patrone: 90951030000 (Papier) 90951030001 (Polyester) Platz für Filtergehäuseentfernung (Ausbauhöhe): ≈ 300 mm	Cartouche: 90951030000 (papier) 90951030001 (polyester) Place pour extraction du boîtier de filtre (hauteur de dégagement): ≈ 300 mm	Cartuccia: 90951030000 (carta) 90951030001 (poliester) Ingombro per rimozione custodia filtro (quota di smontaggio): ≈ 300 mm	Cartucho: 90951030000 (paper) 90951030001 (poliéster) Espacio para quitar carcasa del filtro (altura de desmontaje): ≈ 300 mm
2) The combination of safety valve and intake filter is possible in a modified filter enclosure.	Die Kombination von Sicherheits- ventil und Ansaugfilter ist in einem modifizierten Filtergehäuse möglich.	La combinaison soupape de sécurité et filtre d'aspiration est possible dans un boîtier de filtre modifié.	La combinazione di valvola di sicurezza e filtro di aspirazione è possibile all'interno di una scatola del filtro modificata.	La combinación de válvula de seguridad y filtro de aspiración es posible en una carcasa de filtro modificada.
3) SV 500/1 only available with external suction filter	SV 500/1 nur mit externem Filter verfügbar	SV 500/1 seulement avec filtre d'aspiration externe	SV 500/1 solo con filtro di aspirazione esterno	SV 500/1 sólo con filtro de aspiración externo
* Dimensions for device without base under the sound absorber	Abmaße für Gerät ohne Fuß unter Schalldämpfer	Dimensions pour appareil sans pieds sous le silencieux	Dimensioni del dispositivo senza pedistallo sotto l'insonorizzatore	Dimensiones para aparato sin pie bajo silenciador
• The motor lengths can be found in the device data sheet.	Die Motorlängen sind dem Gerätedatenblatt zu entnehmen.	Les longueurs de moteur sont indiquées dans la fiche de données de l'appareil.	Per le lunghezze dei motori, fare riferimento alle schede tecniche dei dispositivi.	Las longitudes de motor se indican en la ficha técnica de características del aparato.
• Dimensions in mm	Maßangaben in mm	Mesures en mm	Misure in mm	Dimensiones en mm